

CARDEV®

6S-B

Mobile Offline Filtration System

- Intelligent PLC control
- High / low pressure cutoff
- Filter element change timer
- Large capacity pre-filter with re-usable filter bag
- Integrated sample points – allows connection to ETL ConMon particle monitors / oil sampling



Product Datasheet

FOR SYSTEMS UP TO

10,000
LTRS

TYPICAL FLOW RATE

750
LPH

VOLTAGE OPTIONS

110V 230V

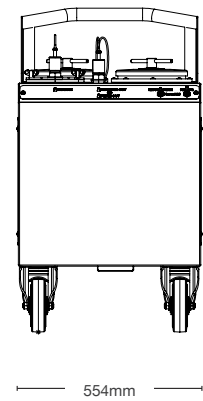
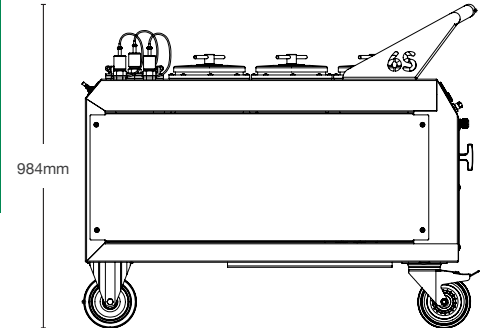
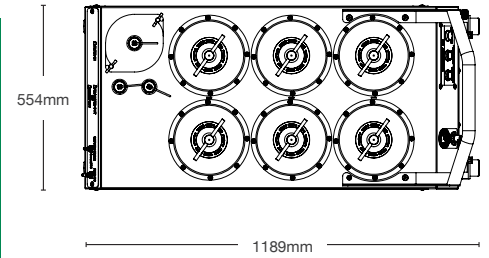
Results



Benefits

- Removes varnish and microparticles (down to less than 1 micron)
- Removes free and dissolved water contamination
- Increases system reliability
- Prevents system corrosion
- Reduces component wear
- Extends oil life and generates CO₂ savings
- Reduces operating costs

Application Examples

Suitable for all types of Industrial applications, e.g:

- Power generation
- Plastic moulding
- Cement Industry
- Manufacturing plants
- Service workshops

Max Operating Temp	IP Rating	Flow Rate (l/h)	Pump Suction Lift	Voltage	Current Draw	Dimensions (mm)		Weight (kg)	Filter Element Type	Retention Capacity (per set)	
						H	W			≤ 15 kg Dirt (kg)	≤ 4.68 Litres of water
60°C	IP55	750	Self-priming to 5.5 metres	110V	≤ 8.5 Amps	984	554	150	Standard fit: 6 x SDFC (oil based fluids)		
				230V	≤ 4.0 Amps	L 1189					

Note: Flow rates, oil cleanliness levels and moisture removal results are based on ISO VG 46 Mineral Oil @ 40°C

ETL FluidExperts

ETL Fluid Experts Ltd
 Environmental Technologies Group Grimbald Crag Road Knaresborough North Yorkshire HG5 8PY United Kingdom
 T +44 (0)1423 522911 F +44 (0)1423 530043 E sales@etfe.com

www.etfluidexperts.com

The specification and photography is for reference only and may be subject to change. ETL Fluid Experts Ltd is part of the Environmental Technologies Group Ltd. All rights reserved.