

4S-B

Mobile Offline Filtration System

- Intelligent PLC control
- High / low pressure cutoff
- Filter element change timer
- Large capacity pre-filter with re-usable filter bag
- Integrated sample points – allows connection to ETL ConMon particle monitors / oil sampling



FOR SYSTEMS UP TO

5000
LTRS

TYPICAL FLOW RATE

500
LPH

VOLTAGE OPTIONS

110V 230V

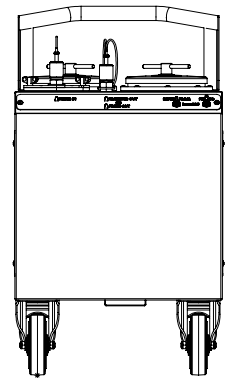
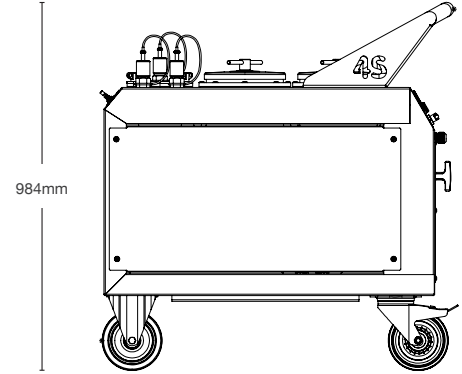
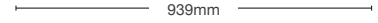
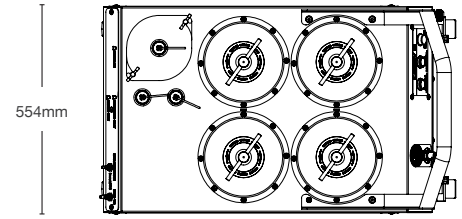
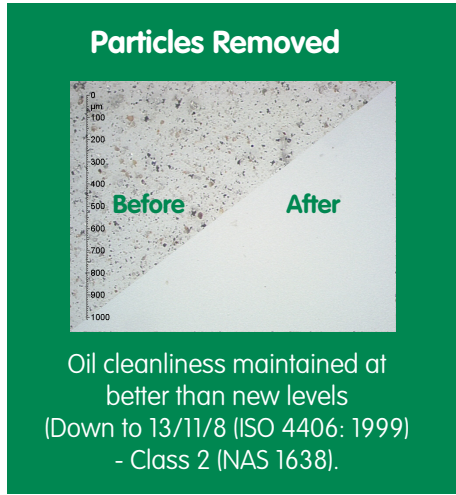
Results



Benefits

- Removes varnish and microparticles (down to less than 1 micron)
- Removes free and dissolved water contamination
- Increases system reliability
- Prevents system corrosion
- Reduces component wear
- Extends oil life and generates CO₂ savings
- Reduces operating costs

Application Examples

Suitable for all types of Industrial applications, e.g:

- Power generation
- Plastic moulding
- Cement Industry
- Manufacturing plants
- Service workshops

Max Operating Temp	IP Rating	Flow Rate (l/h)	Pump Suction Lift	Voltage	Current Draw	Dimensions (mm)		Weight (kg)	Filter Element Type	Retention Capacity (per set)	
						H	W			≤ 10 kg Dirt	≤ 3.12 Litres of Water
60°C	IP55	500	Self-priming to 5.5 metres	110V	≤ 8.5 Amps	984	554	110	Standard fit: 4 x SDFC (oil based fluids)		
				230V	≤ 4.0 Amps	L					
						939					

Note: Flow rates, oil cleanliness levels and moisture removal results are based on ISO VG 46 Mineral Oil @ 40°C

ETL FluidExperts

ETL Fluid Experts Ltd

Environmental Technologies Group Grimbald Crag Road Knaresborough North Yorkshire HG5 8PY United Kingdom
T +44 (0)1423 522911 F +44 (0)1423 530043 E sales@etlfe.com

www.etlfluidexperts.com