

# CARDEV®

## 2S-24V Offline Filtration System

- Can be permanently installed or temporarily mounted to serve multiple items of plant
- 24V DC pumpset
- Over-pressure protection
- Integrated sample points – allows connection to ETL ConMon particle monitors / oil sampling



Product Datasheet

FOR SYSTEMS UP TO  
  
10,000  
LTRS

TYPICAL FLOW RATE  
  
750  
LPH

VOLTAGE OPTIONS  
  
230V

## Results

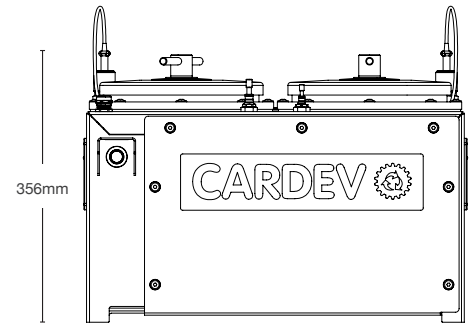
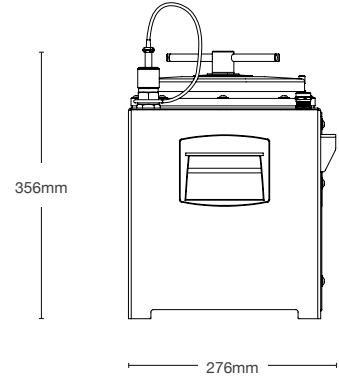
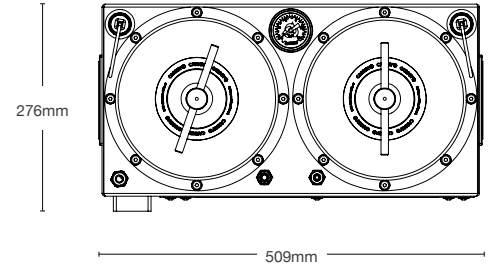
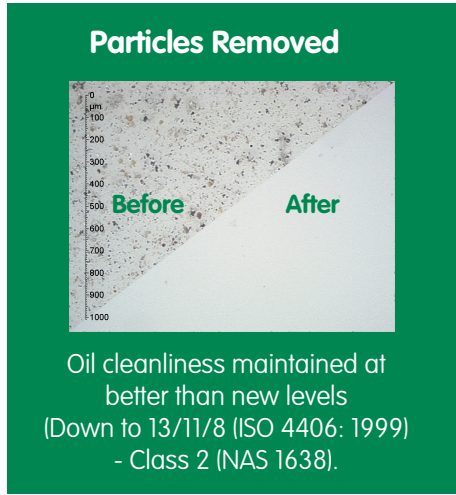

### Benefits

- Removes varnish and microparticles (down to less than 1 micron)
- Removes free and dissolved water contamination
- Increases system reliability
- Prevents system corrosion
- Reduces component wear
- Extends oil life and generates CO<sub>2</sub> savings
- Reduces operating costs

### Application Examples

- Earth moving machines
- Forestry equipment
- Mobile cranes
- Drilling/piling equipment
- Static hydraulic systems

### Optional Accessories

- Magnetic Mounting Kit (KIT-MAG, 4 pcs.)
- Anti Vibration Kit (KIT-AV, 4 pcs)
- Digital Flow meter (FLOW-OIL-1)

Max Operating Temp	IP Rating	Flow rate (l/h)	Pump Suction Lift	Voltage	Current Draw	Dimensions (mm)		Weight (kg)	Filter Element Type	Retention Capacity (per set)	
						H	W			≤ 5 kg Dirt (kg)	≤ 1.56 Litres of water
70°C	IP44	220	Self-priming to 2.4 metres	24V	3 Amps	356	509	45.5	Standard fit: 2 x SDFC (oil based fluids)	≤ 5 kg Dirt (kg)	≤ 1.56 Litres of water
						L					
						276					

Note: Flow rates, oil cleanliness levels and moisture removal results are based on ISO VG 46 Mineral Oil @ 40°C

**ETL FluidExperts**

ETL Fluid Experts Ltd  
 Environmental Technologies Group Grimbald Crag Road Knaresborough North Yorkshire HG5 8PY United Kingdom  
 T +44 (0)1423 522911 F +44 (0)1423 530043 E sales@etfe.com

[www.etfluidexperts.com](http://www.etfluidexperts.com)

The specification and photography is for reference only and may be subject to change. ETL Fluid Experts Ltd is part of the Environmental Technologies Group Ltd. All rights reserved.